

ZDG-376A Low Speed Air Die Grinder

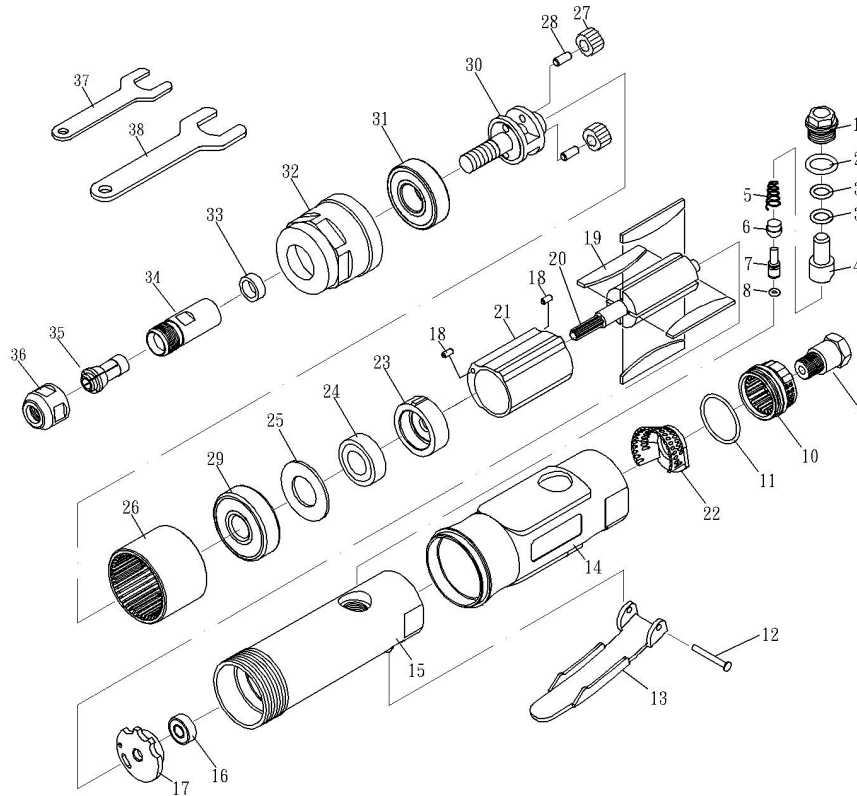

ZDG-376A Low Speed Air Die Grinder

TECHNICAL DATA

0.5HP Die Grinders
 Collet Size : 1/4(6) inch(mm)
 Net Weight : 1.5(0.7) Lbs.(kg)
 Length : 7.8(200) inch(mm)

Free Speed : 3600 R.P.M.
 Air Inlet Size : 1/4 inch-NPT/PT
 Min. Hose Size : 3/8(10) inch(mm)
 Avg. Air Cons. : 3.7 cfm

PARTS LIST

Index	Part #	Description	Q'ty	Index	Part #	Description	Q'ty
1	ZDG-376A-01	SCREW	1	20	ZDG-376A-20	ROTOR (9T)	1
2	ZDG-376A-02	O-RING (P-12)	1	21	ZDG-376A-21	CYLINDER	1
3	ZDG-376A-03	O-RING (P8)	2	22	ZDG-376A-22	CONE MUFFLER	1
4	ZDG-376A-04	AIR REGULATOR	1	23	ZDG-376A-23	FRONT PLATE	1
5	ZDG-376A-05	SPRING	1	24	ZDG-376A-24	BEARING (608ZZ)	1
6	ZDG-376A-06	VALVE STEM BUSHING	1	25	ZDG-376A-25	WASHER	1
7	ZDG-376A-07	VALVE STEM	1	26	ZDG-376A-26	GEAR LINK	1
8	ZDG-376A-08	O-RING (3.5*1.4)	1	27	ZDG-376A-27	IDLER GEAR (16T)	2
9	ZDG-376A-09	AIR INLET	1	28	ZDG-376A-28	IDLER GEAR PIN	2
10	ZDG-376A-10	EXHAUST SLEEVE	1	29	ZDG-376A-29	BEARING (6001Z)	1
11	ZDG-376A-11	O-RING (26.7*1.78)	1	30	ZDG-376A-30	GEAR PLATE	1
12	ZDG-376A-12	SPRING PIN	1	31	ZDG-376A-31	BEARING (6200ZZ)	1
13	ZDG-376A-13	LEVER	1	32	ZDG-376A-32	CLAMP NUT	1
14	ZDG-376A-14	PROTECTING RUBBER	1	33	ZDG-376A-33	WASHER	1
15	ZDG-376A-15	HOUSING	1	34	ZDG-376A-34	SPINDLE	1
16	ZDG-376A-16	BEARING (696ZZ)	1	35	ZDG-376A-35	COLLET	1
17	ZDG-376A-17	REAR PLATE	1	36	ZDG-376A-36	COLLET NUT	1
18	ZDG-376A-18	PIN	2	37	ZDG-376A-37	STOP SPANNER(14M/M)	1
19	ZDG-376A-19	ROTOR BLADE	4	38	ZDG-376A-38	STOP SPANNER(19M/M)	1