

ZDG-3226 115° Air Angle Die Grinder

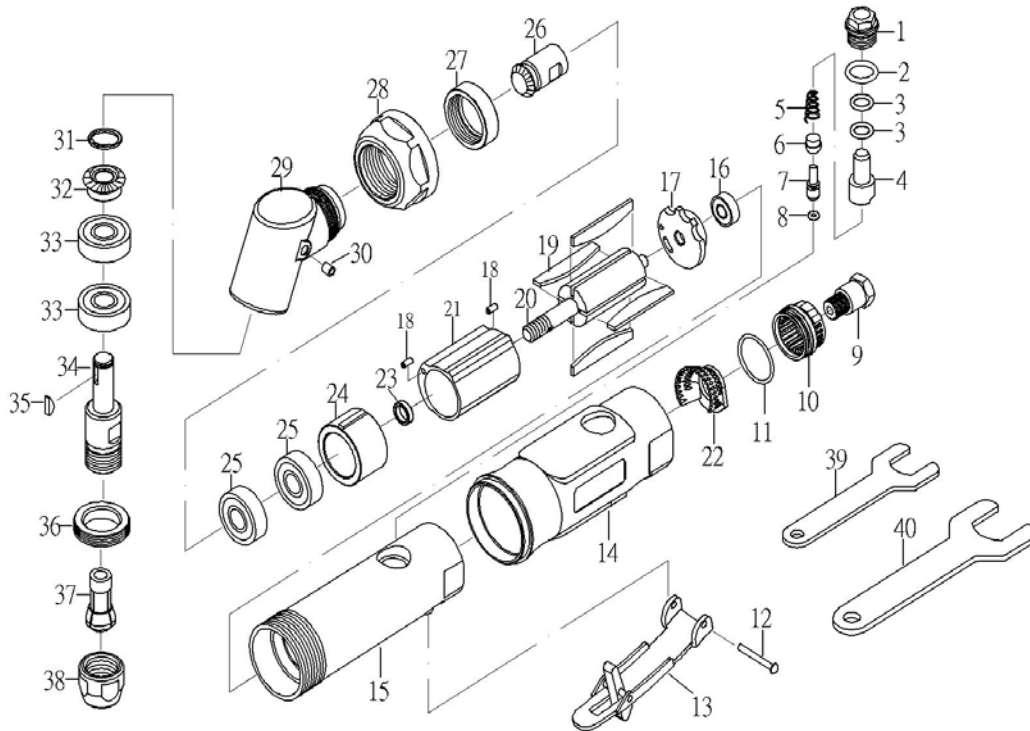

ZDG-3226 115° Air Angle Die Grinder

TECHNICAL

0.5HP Die Grinders
 Collet Size : 1/4(6) inch(mm)
 Net Weight : 1.5(0.7) Lbs.(kg)
 Length : 7(178) inch(mm)

Free Speed : 18000 R.P.M.
 Air Inlet Size : 1/4 inch-NPT/PT
 Min. Hose Size : 3/8(10) inch(mm)
 Avg. Air Cons. : 3.7 cfm

DATA

PARTS LIST

Index	Part #	Description	Q'ty	Index	Part #	Description	Q'ty
1	ZDG-3226-01	SCREW	1	21	ZDG-3226-21	CYLINDER	1
2	ZDG-3226-02	O-RNG (P12)	1	22	ZDG-3226-22	CONE MUFFLER	1
3	ZDG-3226-03	O-RNG (P8)	2	23	ZDG-3226-23	BEARING SPACER	1
4	ZDG-3226-04	AIR REGULATOR	1	24	ZDG-3226-24	FRONT PLATE	1
5	ZDG-3226-05	SPRING	1	25	ZDG-3226-25	BEARING (608ZZ)	2
6	ZDG-3226-06	VALVE STEM BUSHING	1	26	ZDG-3226-26	BEVEL GEAR (18T)	1
7	ZDG-3226-07	VALVE STEM	1	27	ZDG-3226-27	NUT	1
8	ZDG-3226-08	O-RNG (3.5*1.4)	1	28	ZDG-3226-28	CLAMP NUT	1
9	ZDG-3226-09	AIR INLET	1	29	ZDG-3226-29	ANGLE HOUSING	1
10	ZDG-3226-10	EXHAUST SLEEVE	1	30	ZDG-3226-30	OIL CUP	1
11	ZDG-3226-11	O-RNG (26.7*1.78)	1	31	ZDG-3226-31	SNAP RING	1
12	ZDG-3226-12	SPRING PIN	1	32	ZDG-3226-32	BEVEL GEAR (20T)	1
13	ZDG-3226-13	LEVER	1	33	ZDG-3226-33	BEARING (609ZZ)	2
14	ZDG-3226-14	PROTECTING RUBBER	1	34	ZDG-3226-34	SHAFT	1
15	ZDG-3226-15	HOUSING	1	35	ZDG-3226-35	KEY	1
16	ZDG-3226-16	BEARING (696ZZ)	1	36	ZDG-3226-36	CLAMP NUT	1
17	ZDG-3226-17	REAR PLATE	1	37	ZDG-3226-37	COLLET	1
18	ZDG-3226-18	PIN(2.5*6L)	2	38	ZDG-3226-38	COLLET NUT	1
19	ZDG-3226-19	ROTOR BLADE	4	39	ZDG-3226-39	STOP SPANNER (14mm)	1
20	ZDG-3226-20	ROTOR	1	40	ZDG-3226-40	STOP SPANNER (19mm)	1